

DS1100

Ultra Compact Cost-effective Laser Scanner

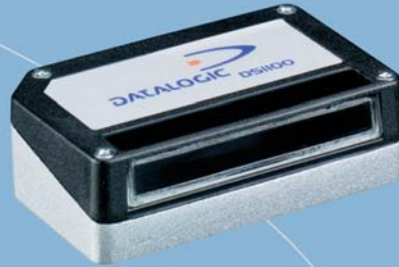

General Description

Datalogic's **DS1100** offers the best cost-effective industrial solution for OEM applications.

Specifically designed for easy integration into OEM equipment, the **DS1100** provides very compact dimensions, light weight and, obviously, Datalogic's recognized excellent scanning performance.

Many applications and customers' needs have been analyzed and taken into great consideration during the **DS1100** product development. Thanks to these studies, direct and 90° output window versions have the same compact dimensions, allowing very flexible installation. The motor can be switched off and on via software commands, in accordance with application needs, increasing product life and silence during use. Set-up procedures are very easy to follow so the scanner can be quickly configured through WINHOST™, the intuitive set-up software.

The **DS1100** covers a wide reading area, scans very close to the output window and grants optimized performance on high resolution codes, thanks to a full range of specific models.

The perfect combination of a powerful RISC decoder with reliable decoding algorithms and impressive optical performance assure the highest read rate and accuracy even on damaged or poorly printed bar codes.

Integration and connection with existing control systems, PCs or PLCs, is very easy using the two high speed serial interfaces. Multi-point scanning configurations are available using Master-Slave or Multiplexer connections.

The **DS1100** is equipped with IP65 rugged industrial housing and is also available as an embedded module for specific applications.

Features

- > **Scanning speed of 500 scans/s**
- > **Motor on/off software commands**
- > Cost-effective
- > Very compact dimensions for both direct/90° reading window models
- > Wide reading width at a short reading distance
- > Lightweight <100 g (<3.53 oz)
- > Dual high speed serial interface (RS232/RS485)

Applications

- > Chemical and blood analyzers
- > Pharmaceutical code verifiers
- > Automatic teller machines (ATMs)
- > Printing machines
- > Video rental machines
- > Film processing machines
- > Assembly lines
- > Work-in-process & Quality control

Specifications

ELECTRICAL CHARACTERISTICS

POWER SUPPLY 5 VDC \pm 5% (4 to 30 VDC with converter)
 POWER CONSUMPTION 1.5 W

MECHANICAL CHARACTERISTICS

WEIGHT (without cable) <100 g (<3.53 oz)
 CASE MATERIAL Magnesium (body) + Polycarbonate (cover)

PERFORMANCE

LIGHT SOURCE Visible laser diode (650 nm)
 SCANNING SPEED 500 scans/s
 MAX. RESOLUTION
 1xxx models 0.20 mm (8 mils)
 2xxx models 0.12 mm (5 mils)
 MAX. READING DISTANCE
 1xxx models 220 mm (8.7 in) on 0.50 mm (20 mils) code res.
 2xxx models 110 mm (4.3 in) on 0.30 mm (12 mils) code res.
 MAX. DEPTH OF FIELD
 1xxx models 190 mm (7.5 in) on 0.50 mm (20 mils) code res.
 2xxx models 100 mm (3.7 in) on 0.30 mm (12 mils) code res.
 APERTURE ANGLE 70 degrees
 RASTER APERTURE 15 mm (0.6 in) at 220 mm (8.7 in)
 READABLE CODES Code 2/5, Code 39, Code 93, Code 128, EAN/UPC, EAN 128, Codabar, Plessey, Pharmacode
 MULTILABEL READING Up to 6 different codes in the same reading phase
 COMM. INTERFACES RS232 + RS485 half duplex
 BAUD RATE Up to 115,200 bauds
 INPUT SIGNALS One programmable digital input and One External Trigger digital input
 OUTPUT SIGNALS Two programmable digital outputs
 PROGRAMMING METHOD Via serial port (WINHOST™)
 OPERATING MODES 'On line', 'Serial On-line', 'Automatic', 'Test'
 MOTOR CONTROL Motor on/off software commands
 LED INDICATORS 'Power On', 'Ext Trigger', 'Laser On', 'Good Read', 'Tx Data'
 LASER CLASSIFICATION IEC 825-1 Class 2; CDRH Class II
 LASER CONTROL Security system to turn laser off in case of motor slow down or failure

ENVIRONMENT
 OPERATING TEMPERATURE 0 to 45 °C (32 to 113 °F)
 STORAGE TEMPERATURE -20 to 70 °C (-4 to 158 °F)
 HUMIDITY 90% non condensing
 VIBRATION RESISTANCE IEC 68-2-6 test FC 1.5 mm; 10 to 55 Hz; 2 hours on each axis
 SHOCK RESISTANCE IEC 68-2-27 test EA 30 G; 11 ms; 3 shocks on each axis
 PROTECTION CLASS IP65

Dimensions

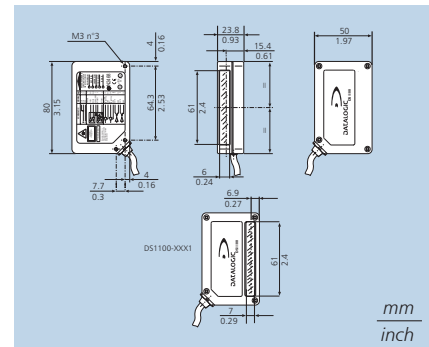

Reading Diagrams

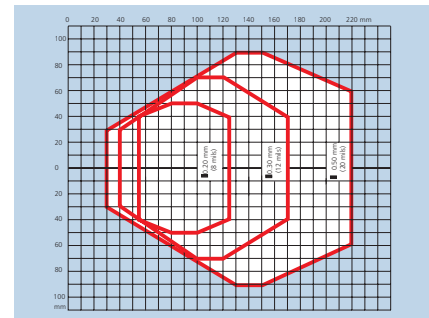

Standard resolution models

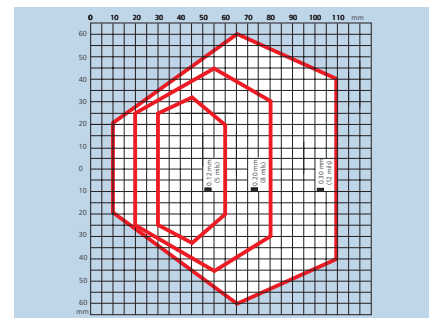

High resolution models

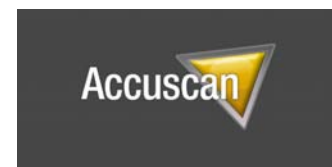

Product and Company names and logos referenced may be either trademarks or registered trademarks of their respective companies. We reserve the right to make modifications and improvements.

